

BENCH CENTER WITH ROLLER TAILSTOCKS

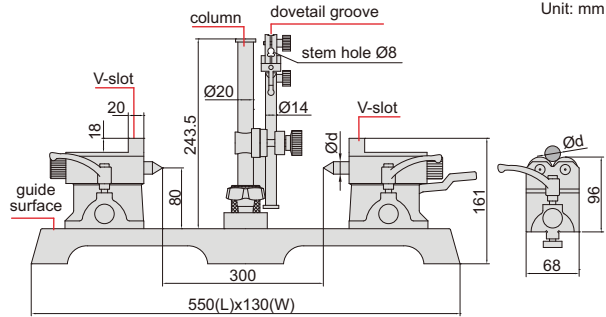

roller tailstocks (included)

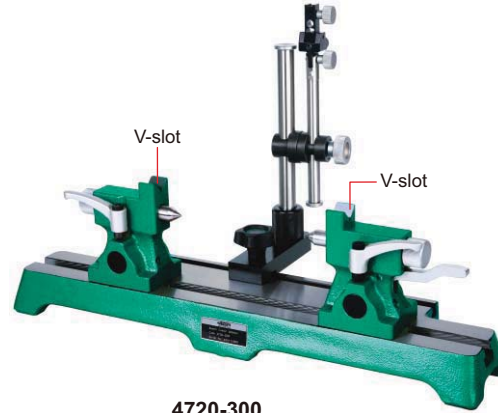
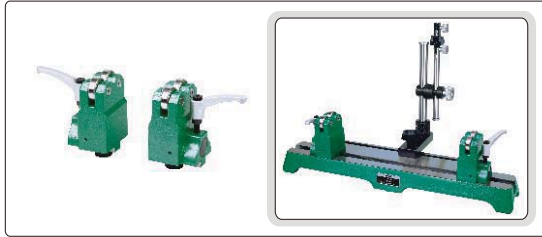

4720-300

- Hardened cast-iron guide surface
- Supplied with V-slot/center tailstocks and roller tailstocks
- V-slot for cylinder $\text{Ø}4\sim 22\text{mm}$
- Roller for cylinder $\text{Ø}5\sim 100\text{mm}$

Code	Parallelism*	Runout accuracy	Center height	Distance between two centers	Diameter of center ($\text{Ø}d$)	Taper of center	Load
4720-300	0.01mm	2 μm	80mm	300mm	16mm	MT1	25kg (40kg for roller tailstocks)

*Parallelism of two centers to the guide surface